

General Information

Safety recommendations

As high pressures/forces constitute a potential safety risk, the following instructions must be considered:

- The equipment should only be operated by trained personnel
- Always follow the operating instructions
- Check the hydraulic nut and all accessories carefully before use. Never use even slightly damaged components
- Make sure all air has been removed from the hydraulic system, before putting the equipment under pressure
- Do not use the hydraulic nut for other applications than mounting/dismounting bearings
- Always use a pressure gauge
- Always prevent the workpiece/tool from being ejected upon sudden release of pressure (e.g. by use of retaining nut)
- Do not exceed the maximum permitted piston displacement
- Use protective goggles
- Never modify the unit
- Use original parts only
- Only use clean, recommended hydraulic oils (e.g. SKF LHM 300, LHDF 900 or similar)

In case of any uncertainties as regards the use of the hydraulic nut, contact SKF.

Description

The hydraulic nut has proved to save considerable effort when mounting or dismounting rolling bearings with tapered bores. It comprises two main components: a steel ring with a groove in one side face and internal thread (a) and an annular piston which rests in the groove (b). The seal (c) between the two parts consists of two O-rings. When oil is pumped into the pressure chamber (d), the piston is pressed out with a force which normally is sufficient for mounting and dismounting rolling bearings.

The outer ring is provided with an unthreaded hole (g) to hold a dial indicator (h). The measuring tip of the indicator will rest against the shoulder of the piston indicating the axial travel of the same.

Note

The drive-up distance can be used to determine correct mounting; [click here](#) for more info.

To connect the oil hose, there are two threaded holes, one in the side face of the steel ring (e) and the other in its cylindrical outside surface (f). The hole which is not in use is plugged with a ball plug, that is supplied with the nut.

All hydraulic nuts are equipped with nipple **729832 A** for quick connection to the oil supply.

A spare set of O-rings, a maintenance set and a tommy section bar for tightening the nut are all included as standard.

Load carrying ability

SKF hydraulic nuts are designed to withstand the pressure normally encountered when rolling bearings are mounted or dismounted. The maximum pressure in absolute terms depends on the piston displacement, the actual nut size and whether back-up rings are used or not. The smaller the nut and the shorter the piston displacement, the higher pressure the nut can take. A back-up ring will also increase the load carrying ability, especially for bigger nuts.

Unthreaded execution

All HMV-nuts are also available in an unthreaded execution with an addition to the designation of /A101. All major dimensions are exactly the same as for the corresponding HMV-nut. For bore diameters please [click here](#).

Heavy duty series of hydraulic rings

A special heavy duty series of hydraulic rings, mainly for fitting marine components, are also available from SKF. They are normally unthreaded and can take pressure up to 70 MPa (10,000 psi). [Click here](#) for detailed information.



How to apply the nut

To enable easy mounting especially for larger nuts, it is important that the nut is properly centred on the mating thread before screwed on. For bigger nuts a proper support has to be created under the nut. When the bearing is mounted on a sleeve, make sure that the sleeve is straight, i.e. the thread is aligned over the slotted part of the sleeve. It is recommended to always use a thread lubricant before applying the nut on the mating thread. When the nut is to be applied, a tommy bar is provided with the nut to be used as a handle. This is inserted in one of the four unthreaded holes in the outside cylindrical surface, or in one of the two holes on the side surface.

How to generate the pressure

The requisite pressure can best be produced using a pump which will give at least 100 MPa (14,500 psi). Suitable pumps from the SKF range are **729124** for nuts up to and including size 54, and **TMJL 100**, **TMJA 70E**, **728619** or **TMJL 50** for larger sizes. Oil having a viscosity of approx. 300 mm²/s at the operating temperature, e.g. SKF mounting fluid **LHM 300**, should be used as pressure medium. Less viscous oils should be used, for mounting in the cold. When connecting the pump be sure that all air is removed from the hydraulic system. This can be done by opening one of the plugs and by injecting oil simultaneously until leakage occurs.

- a. internally threaded steel ring
- b. annular piston
- c. O-rings
- d. pressure chamber

- u. pressure chamber
- e. connection hole in side face
- f. connection hole in outside surface
- g. unthreaded hole for dial indicator
- h. dial indicator

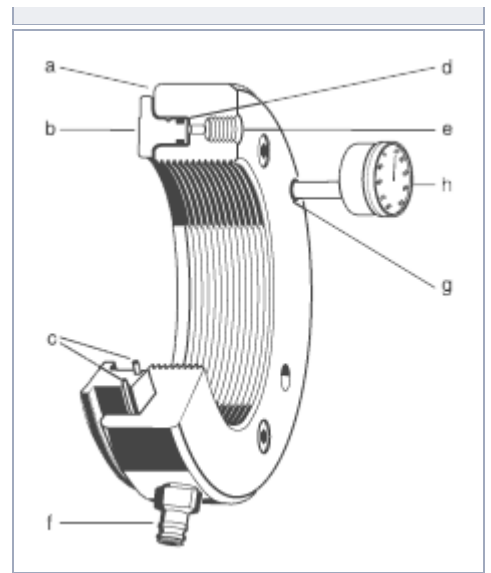

Mounting of bearings

The nut should be carefully screwed on to a threaded section of the shaft or the sleeve until it abuts the bearing inner ring (fig. 1, 2), the withdrawal sleeve (fig. 3) or a special support nut/plate (fig. 4). It is important that as much as possible, but not less than 80% of the thread of the hydraulic nut is engaged. If this is not possible, a help ring to support underneath the nut is necessary. The piston should then be fully retracted into the ring. A pump is used to inject pressurised oil into the nut. The permissible stroke (axial displacement) has been chosen to enable all bearings having bores with a taper of 1:12 or 1:30 to be mounted in a single operation. The permitted piston displacement, which is indicated by a groove in the outside of the piston, should however never be exceeded. After mounting has been completed, the return valve of the pump should be opened so that the pressurised oil can leave the nut. To completely empty the nut, the piston has to be returned to its original position. This is most easily accomplished by screwing the nut further up the shaft or sleeve thread. For correct interference fit and/or internal clearance in the bearing please [click here](#) (or see publication MP502; included with the HMV nut) or publication 4555 E (for CARB®).

Mounting

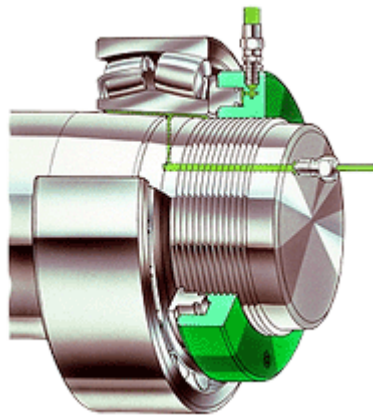

1. HMV E nut for driving the bearing onto a tapered seating.

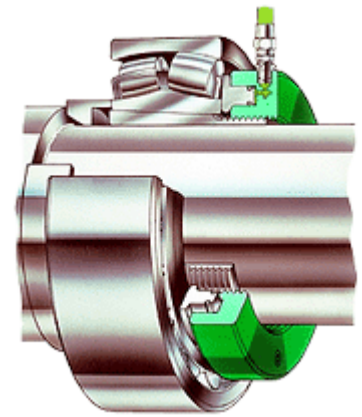

2. HMV E nut for driving the bearing onto an adapter sleeve.

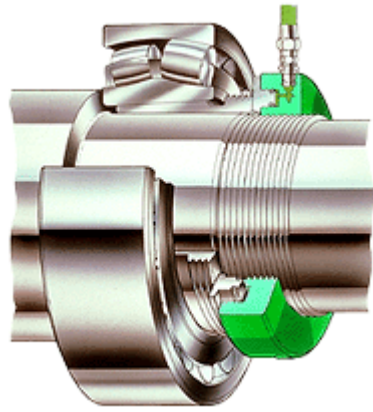

3. HMV E nut screwed onto the shaft for driving in a withdrawal sleeve.

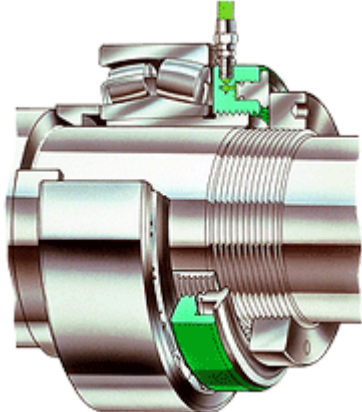

4. HMV E nut and special stop nut for driving in a withdrawal sleeve.

Dismounting of bearings

When dismounting rolling bearings from withdrawal or adapter sleeves, the hydraulic nut is screwed on to the sleeve thread until it rests against the bearing inner ring (fig. 5), or against a special support ring (fig. 6). By displacing the piston, the sleeve will be withdrawn from the bearing bore, or the bearing will be pressed off the adapter sleeve.

Dismounting



5. HMV E nut used to free a withdrawal sleeve.

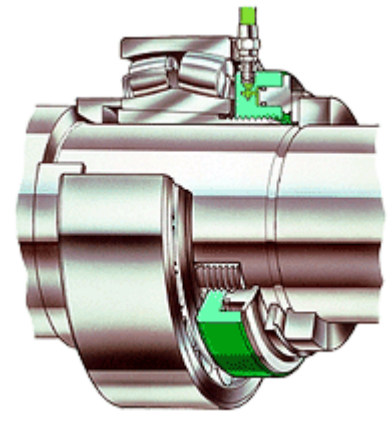

6. HMV E nut and stop ring in position to press an adapter sleeve free.

Maintenance

When the nut is not in use, it should be protected against rust and any oil supply leads should be plugged to prevent entry of dirt.

Dimensions

In the tables on following pages dimensions are given for SKF standard hydraulic nuts HMV ... (metric), and HMVC... (inch) as well as for hydraulic nuts without threads. The nuts may also be made to other sizes, with special threads or unthreaded bores. Further information will be provided on request.

In case of leakage

If oil leaves the hydraulic nut when the piston is operated, this generally means the seal is torn or damaged and must be replaced. To do this, the piston has to be pressed out of the ring. To facilitate this operation, three auxiliary holes with closure nipples are provided in the full face of the ring. Using threaded pins, which are supplied with the nut, the piston can be pushed out of the ring. The O-rings are then removed, the grooves cleaned and the new O-rings put in position. If necessary, grease can be used to keep the new O-rings in the correct position during the replacement operation. A reserve set of O-rings are also supplied with the nut. Additional replacement rings if needed can be obtained from SKF.

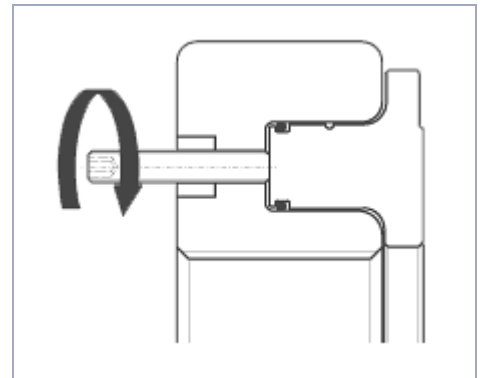

Replacement parts

Description	Designation
O-rings	Nut designation followed by /233983, e.g. HMV 10/233983
Ball plug	233950 E
Quick connection nipple	729832 A
Maintenance set	HMVM 10/29 (nut size 10 to 29)
(threaded pins, copper rings, hexagonal keys)	HMVM 30/69 (nut size 30 to 69)
	HMVM 70/200 (nut size 70 to 200)

Accessories

The following pumps are recommended for the various nut sizes

HMV(C) 10E - HMV(C) 54E	729124 / TMJL 50 / TMJL 100 / 728619 E / TMJA 70E
HMV(C) 56E - HMV(C) 92E	TMJL 50 / TMJL 100 / 728619 E / TMJA 70E
HMV(C) 94E - HMV(C) 200E	TMJL 50 / 728619 E
Mounting fluid	LHMF 300/5
Dial indicators	TMCD 5P (parallel dial, 0-5 mm)
	TMCD 1/2R (right angle dial 0-0.5 in)
	TMCD 10R (right angle dial, 0-10 mm)
Precision gauge	TMJG 100D (100 MPa / 15000 psi, G 1/4 connection)

