

Application

The pump is suitable for SKF hydraulic nuts (\leq HMV 54), and for mounting or dismantling bearings or components with an interference fit applying the SKF oil injection method, where a maximum pressure of 100 MPa (14,500 psi) is required.

Description

The pump 729124 is supplied with a 1.500 mm (4,9 ft) pressure hose 729126, quick connection coupling 729831 A, quick connection nipple 729832 A and transport box. The pump is filled with SKF Mounting Fluid LHMf 300 (viscosity 300 mm²/s at 20 °C (1,400 SUS at 68 °F)).



Technical data

Designation	729124
Maximum pressure	100 MPa (14,500 psi)
Volume/stroke	0,5 cm ³ (0.03 in ³)
Oil container capacity	250 cm ³ (15 in ³)
pressure hose	1.500 mm (59 in)
Quick connection nipple	G 1/4
Total weight	3,5 kg (8 lb)

Replacement parts

Designation	Description
729108	Nipple for pressure gauge
729124-1	Pump body
729124-2	Transport box
729124-3	Repair kit
729124-4	Release valve and spindle
729124-5	Oil container tube
729831 A	Quick connection coupling 1/4" G
729832 A	Quick connection nipple 1/4" G
729126	Pressure hose 1,5 m (4.9 ft)
1077587/2	Pressure gauge

Special executions

729124 A

For applications in which space does not permit the use of a quick connection coupling and nipple, e.g. AOH sleeves, a special pump design, designation 729124 A, is available consisting of:

729108	nipple for pressure gauge
729124-1	pump body
729124-2	transport box
1077587/2	pressure gauge
1020612 A/500	high pressure pipe with special connection nipple 729107 plus washer

729124 SRB

For use with the [Drive-up method](#) the 729124 is also available with the high precision gauge [TMJG 100D](#). The suitable size range for the 729124 SRB are nuts up and including HMV 54E.

The complete pump kit consists of:

729108	nipple for pressure gauge
729124-1	Pump body
TMJG 100D	Precision digital gauge
729126	High pressure hose; 1,5 m
729831 A	Quick connection coupling
729832 A	Quick connection nipple
LHMf 300/1	Mounting fluid, 1 litre can
728245/3	Transport box

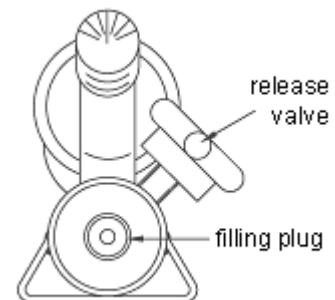

Rear end view

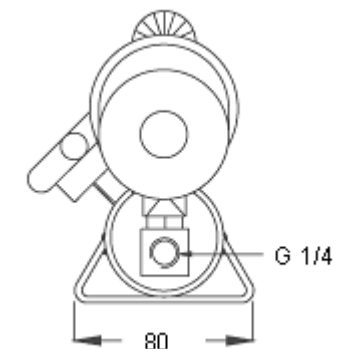

Front end view

