

SKF Large induction heater TIH 220m

Large bearing heater with high heating capacity of up to 300 kg bearing

The large induction heater TIH 220m is a reliable and robust induction heater from the TIH...m range suitable for heating bearings up to a maximum weight of 300 kg (660 lbs) and solid components up to a maximum weight of 150 kg (330 lbs). Advanced design of the power electronics including current and overheating control, combined with user friendly features such as sliding arms and remote control are standard to the TIH...m range.

Maximum efficiency is achieved by placing the induction coil outside the heater's housing, in the centre of the bearing, resulting in shorter heating time and lower energy consumption. The LED operating display and control panel are integrated in a remote control, which makes the heater easy to use. To suit different operating voltages worldwide, the TIH 220m is available in different voltage variants.



- Capable of heating a 220 kg (460 lbs) bearing in just 20 minutes, saving time and energy
- Supplied standard with two yokes, allowing bearings with a bore diameter from 60 mm (2,3 in) up to a maximum weight of 300 kg (660 lbs) to be heated
- 2-step power setting and smaller yoke facilitates efficient heating of smaller bearings with a lower power consumption
- Temperature mode pre-set at 110 °C (230 °F), helps prevent bearing overheating
- Automatic demagnetisation
- 3 year warranty

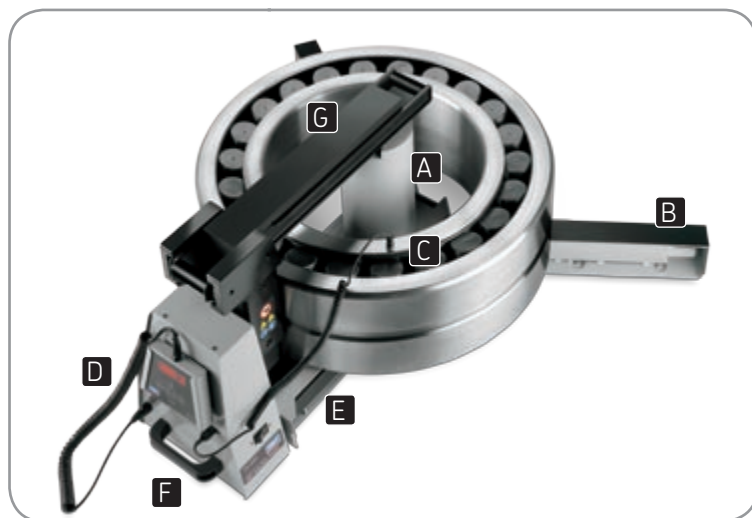

- A Induction coil outside the heater's housing allows shorter heating time and lower energy consumption
- B Foldable bearing support arms facilitate the heating of larger diameter bearings
- C Magnetic temperature probe helps prevent bearing overheating
- D Easy-to-use control panel and LED display integrated in a remote control
- E Internal yoke storage for the smaller yoke reduces the risk of yoke damage or loss
- F Integrated carrying handles provide excellent grip when moving the TIH 220m around
- G Sliding arm allows easy and quick bearing replacement



Technical data

Designation	TIH 220M/LV, TIH 220M/MV
SKF m ₂₀ performance	220 kg (460 lbs)
Voltage, V/Hz	TIH 220M/LV: 200-230V/50-60Hz TIH 220M/MV: 400-460V/50-60Hz
Work piece:	
– Maximum weight	300 kg (661,4 lb)
– Maximum bore diameter	60 – 600 mm (2,3 – 23,6 in)
Temperature control:	
– Range	0 – 250 °C (32 – 482 °F)
– Magnetic probe	Yes, K-type
– Accuracy (electronics)	± 2 °C (± 3,6 °F)
Time control:	
– Range	0 – 60 minutes
– Accuracy	± 0,01 sec.
Maximum temperature (approx.)	400 °C (750 °F)
Thermometer mode	Yes
Bearing mode (pre-set at 110 °C/230 °F)	Yes
Power reduction	2-step; 50 – 100%
Demagnetisation according to SKF norms (automatic)	Yes (<2 A/cm)
Can heat sealed bearings	Yes
Can heat pre – greased bearings	Yes
Error guiding codes	Yes
Thermal overload protection	Yes
Maximum magnetic flux	1,55 T
Control panel	Key board with LED in remote control
Operating area (w × h)	250 × 255 mm (9,8 × 10 in)
Coil diameter	140 mm (5,5 in)
Dimensions (w × d × h)	750 × 290 × 440 mm (29,5 × 11,4 × 17,3 in)
Total weight, including yokes	86 kg (189 lbs)
Maximum power consumption	10,0-11,5 kVA (400-460V)
Number of standard yokes	2
Standard yokes	70 × 70 × 430 mm (2,8 × 2,8 × 16,9 in), for heating bearings with bore diameter of 100 mm (3,9 in) and larger 40 × 40 × 430 mm (1,5 × 1,5 × 16,9 in), for heating bearings with bore diameter of 60 mm (1,6 in) and larger
Core cross section	70 × 70 mm (2,8 × 2,8 in)
Yoke storage	Yes
Sliding arm	Yes, 70 × 70 × 430 mm (2,8 × 2,8 × 16,9 in) yoke only
Swivel arm	No
Cooling fan	No
Housing material	Steel and glass fibre filled polyamide
Warranty period	3 years

Selection guide

There are no totally restrictive guidelines to follow when choosing your SKF bearing heater. It will depend upon the type and geometrical dimensions of the components you want to heat. Nevertheless, SKF offers the following helpful general selection guide.

SKF m₂₀ concept

“m₂₀” represents the weight (kg) of the heaviest SRB 231 bearing which can be heated from 20 to 110 °C (68 to 230 °F) in 20 minutes. This defines the heater’s power output instead of its power consumption.

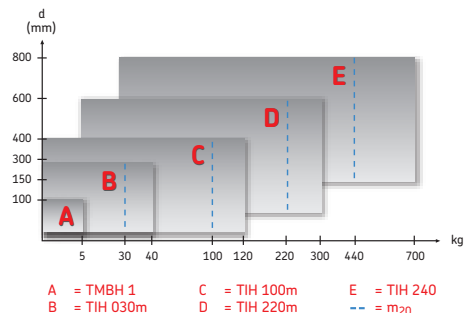

SKF Maintenance Products

© SKF 2007/03

© SKF is a registered trademark of the SKF Group

www.mapro.skf.com
www.skf.com/mount

The contents of this publication are the copyright of the publisher and may not be reproduced (even extracts) unless permission is granted. Every care has been taken to ensure the accuracy of the information contained in this publication but no liability can be accepted for any loss or damage whether direct, indirect or consequential arising out of use of the information contained herein.