

Relubrication interval

The period during which a grease lubricated bearing will function satisfactorily without relubrication is dependent on the bearing type, size, speed, operating temperature and the grease used. The relubrication intervals (hours of operation) obtained from Diagram 1 are valid for bearings in stationary machines where loading conditions are normal. The diagram is based on the use of an age-resistant good quality lithium grease and is valid for bearing temperatures of 70 °C (158 °F) measured on the outer ring. The intervals should be halved for every 15 °C (27 °F) increase above 70 °C (158 °F), but the maximum permissible operating temperature for the grease should obviously not be exceeded. Generally for temperatures above 80 °C (176 °F) a high temperature grease is recommended.

Conversely, if operating temperatures are lower than 70 °C (176 °F), the intervals can be lengthened to about twice the values for operating temperatures of 50 °C (122 °F) and below. It should be noted, however, that relubrication intervals may vary significantly even where apparently similar greases are used.

For small bearings, particularly deep groove ball bearings, the relubrication interval is often longer than the life of the bearing application. Therefore, relubrication is normally not required. In such cases, ball bearings fitted with shields or seals and which are "lubricated-for-life" may be used. Where there is a risk of the grease becoming contaminated, the relubrication intervals should be reduced. This reduction also applies to applications where the grease is required to seal against moisture, e.g. bearings in papermaking machines.



Relubrication

The amount of grease needed for relubrication can be obtained from the equation below

$$G_p = 0,005 D B$$

where

G_p	=	grease quantity, g
D	=	bearing outside diameter, mm
B	=	total bearing width, mm (for thrust bearings, use H = total height)

When operating conditions are such that relubrication can be carried out at infrequent intervals, it is sufficient if the bearing housing is accessible and can be opened easily. The cap of split housings and the cover of one-piece housings can usually be taken off to expose the bearing. After removing the used grease, fresh grease should first be packed between the rolling elements.

Where more frequent relubrication is required provision should be made for regreasing; preferably a grease nipple should be fitted to the housing. A grease gun (lubricator) can then be used. To help ensure that fresh grease actually reaches the bearing and replaces the old grease, the lubrication duct in the housing should either feed the grease adjacent to the outer ring side face, or, better still,

into the bearing, e.g. spherical roller bearings with lubrication groove and holes in the outer ring, figures 1 and 2. After a number of such relubrications the housing should be opened and the used grease removed before fresh grease is added.

Diagram

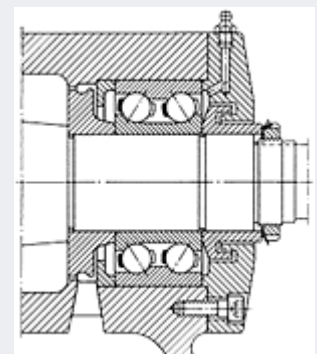

t_f operating hours

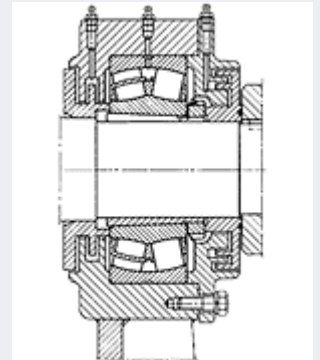
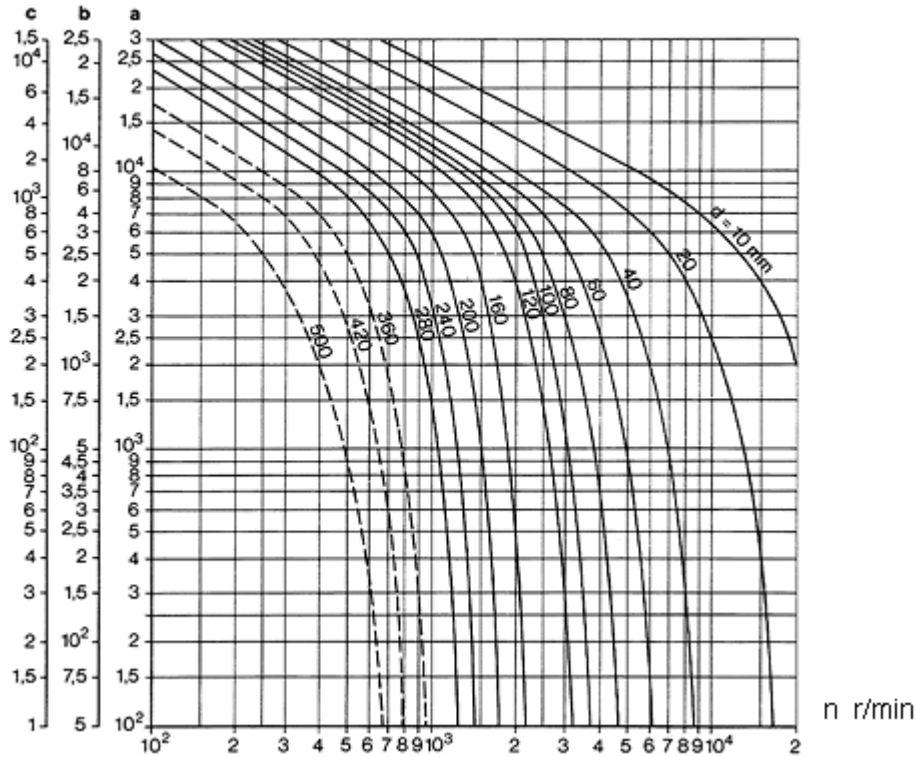

Scale a:	Radial ball bearings
Scale b:	Cylindrical roller bearings, needle roller bearings
Scale c:	Spherical roller bearings, taper roller bearings, thrust ball bearings; full complement cylindrical roller bearings (0,2 tf); crossed cylindrical roller bearings with cage (0,3 tf); cylindrical roller thrust bearings, needle roller thrust bearings, spherical roller thrust bearings (0,5 tf)

DialSet re-lubrication calculation program

DialSet is a calculation program which easily determines the right time setting for your SYSTEM 24 and SYSTEM MultiPoint applications. In addition it recommends when to use LAGD 125 and when to use the LAGD 60. Available on CD-ROM in six languages.

[Click here](#) to download DialSet

Designation: **MP3506**

